

REVISIONS				
ZONE	REV.	DESCRIPTION	DATE	APPROVED
3-B4	2	ADDED 3RD PAGE	2021-04-29	D.WU

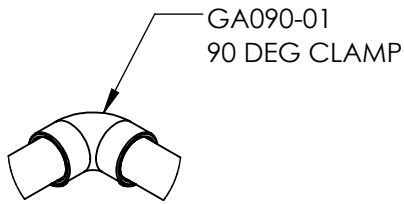

DETAIL A
SCALE 1 : 8

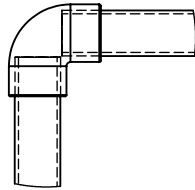

DETAIL B
SCALE 1 : 8

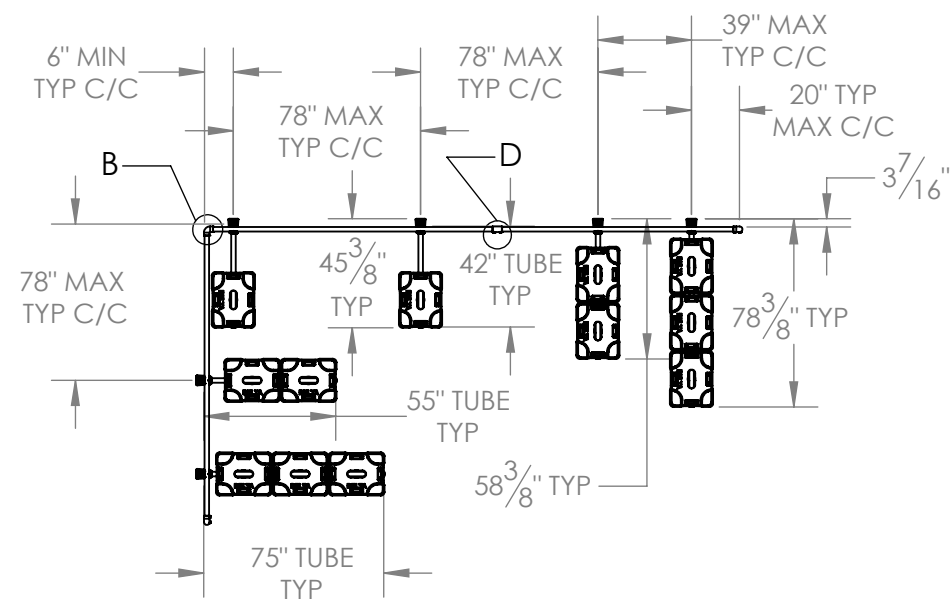
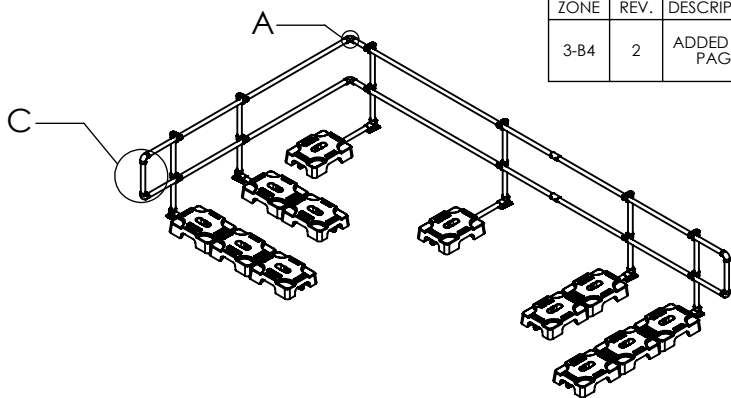

90 DEG CORNERS

END RETURN

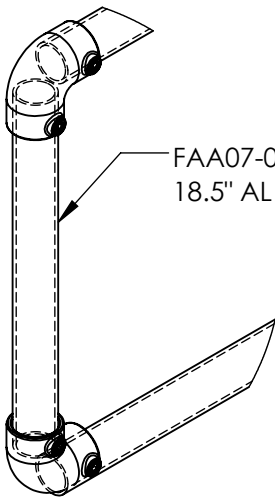

DETAIL C
SCALE 1 : 8

UNION

GA010-01
UNION CLAMP

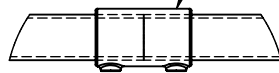

DETAIL D
SCALE 1 : 8

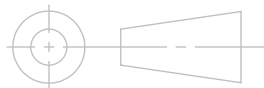

THIRD ANGLE PROJECTION

ALL DIMENSIONS ARE IN INCH
TOUTES LES DIMENSIONS SONT EN POUCE
UNLESS OTHERWISE NOTED
SAUF INDICATION CONTRAIRE

TOLERANCES/TOLÉRANCES:

DIM.	ANG.
X.X ±0.060"	X ±3.00°
X.XX ±0.030"	X.X ±1.00°
X.XXX ±0.015"	X.XX ±0.50°

MACHINED SURFACE FINISH/FINI DE SURFACE MACHINÉ:
Ra : 125 µin

MATERIAL/MATERIEL:
N/A

VOLUME/VOLUME:
N/A

PAINTED/PEINTURE:
N/A

EST WEIGHT/POIDS EST:
825.114 POUNDS

DRAWN BY/ DESSINÉ PAR:
D.WU

CHECKED BY/VÉRIFIÉ PAR:
D.WU

3D FILE NAME/NOM DE FICHER 3D:
TYPICAL DETAIL DRAWINGS A - VSS CLASSIC_REV.1



TITLE/TITRE:
TYPICAL DETAIL DRAWINGS A

PART NUMBER/NUMÉRO DE PIÈCE:
VSS CLASSIC

REV:
2

SIZE/FORMAT: A
SCALE/ÉCHELLE: 1:80
SHEETS/FEUILLES: 1 OF/DE 4

NOTES

- ALL SET SCREWS ARE TO BE TORQUED TO 30LBS/FT UNLESS OTHERWISE SPECIFIED
- GUARDRAILS MUST BE INSTALLED 12" MIN FROM EDGE ON A PARAPET FREE ROOF.

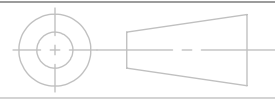
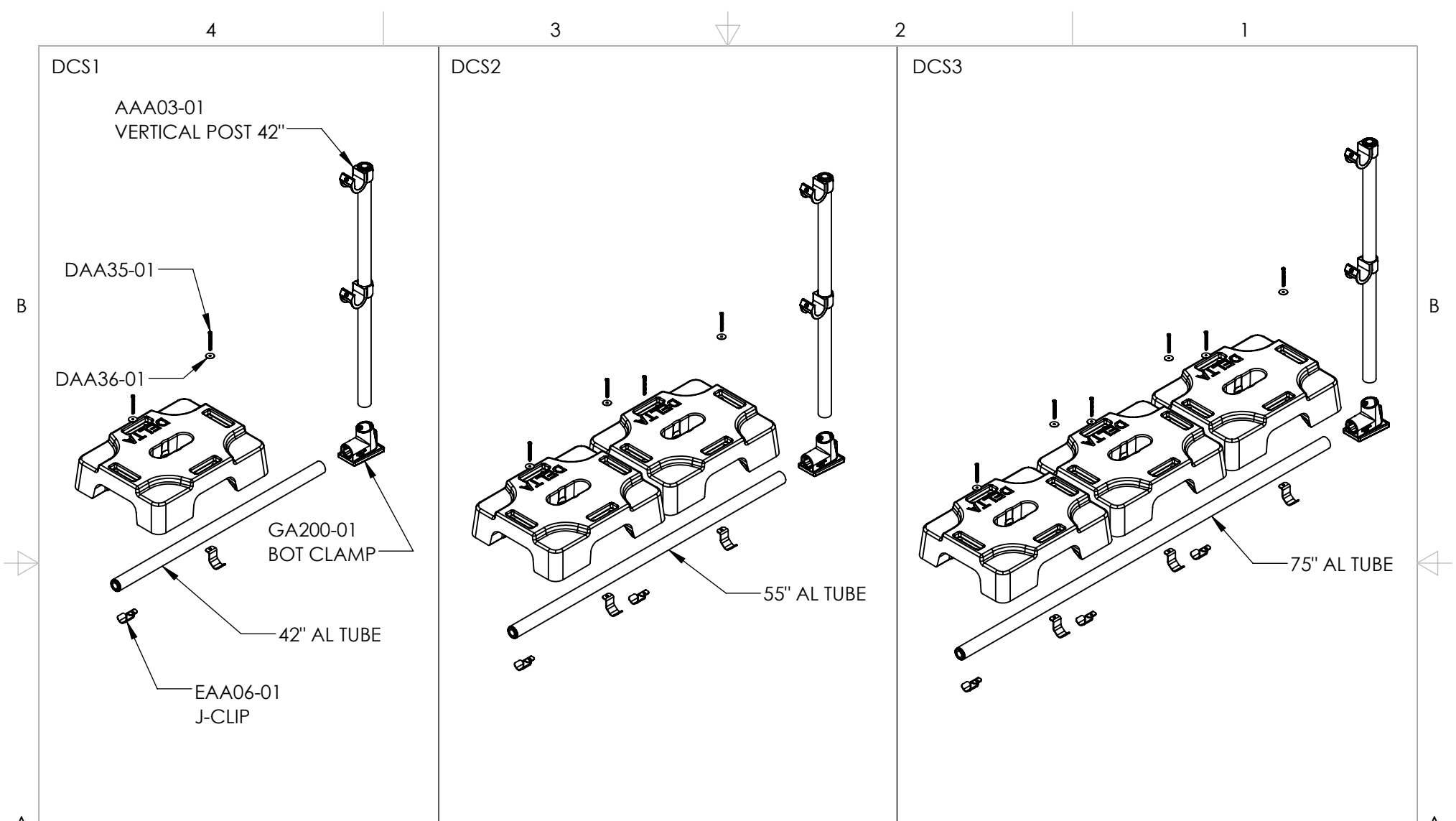

THIRD ANGLE PROJECTION

ALL DIMENSIONS ARE IN INCH
TOUTES LES DIMENSIONS SONT EN POUCE
UNLES OTHERWISE NOTED
SAUF INDICATION CONTRAIRE

TOLERANCES/TOLÉRANCES:

DIM.	ANG.
X.X ±0.060"	X ±3.00°
X.XX ±0.030"	X.X ±1.00°
X.XXX ±0.015"	X.XX ±0.50°

MACHINED SURFACE FINISH/FINI DE SURFACE MACHINÉ:
Ra : 125 µin

MATERIAL/MATERIEL: N/A	3D FILE NAME/NOM DE FICHER 3D: TYPICAL DETAIL DRAWINGS A - VSS CLASSIC_REV.1	
VOLUME/VOLUME: N/A		
PAINTED/PEINTURÉ: N/A		
EST WEIGHT/POIDS EST: 825.114 POUNDS	TITLE/TITRE: TYPICAL DETAIL DRAWINGS A	
DRAWN BY/ DESSINÉ PAR: D.WU	PART NUMBER/NUMÉRO DE PIÈCE: VSS CLASSIC	REV: 2
CHECKED BY/VÉRIFIÉ PAR: D.WU	SIZE/FORMAT: A	SCALE/ÉCHELLE: 1:20
		SHEETS/FEUILLES: 2 OF/DE 4

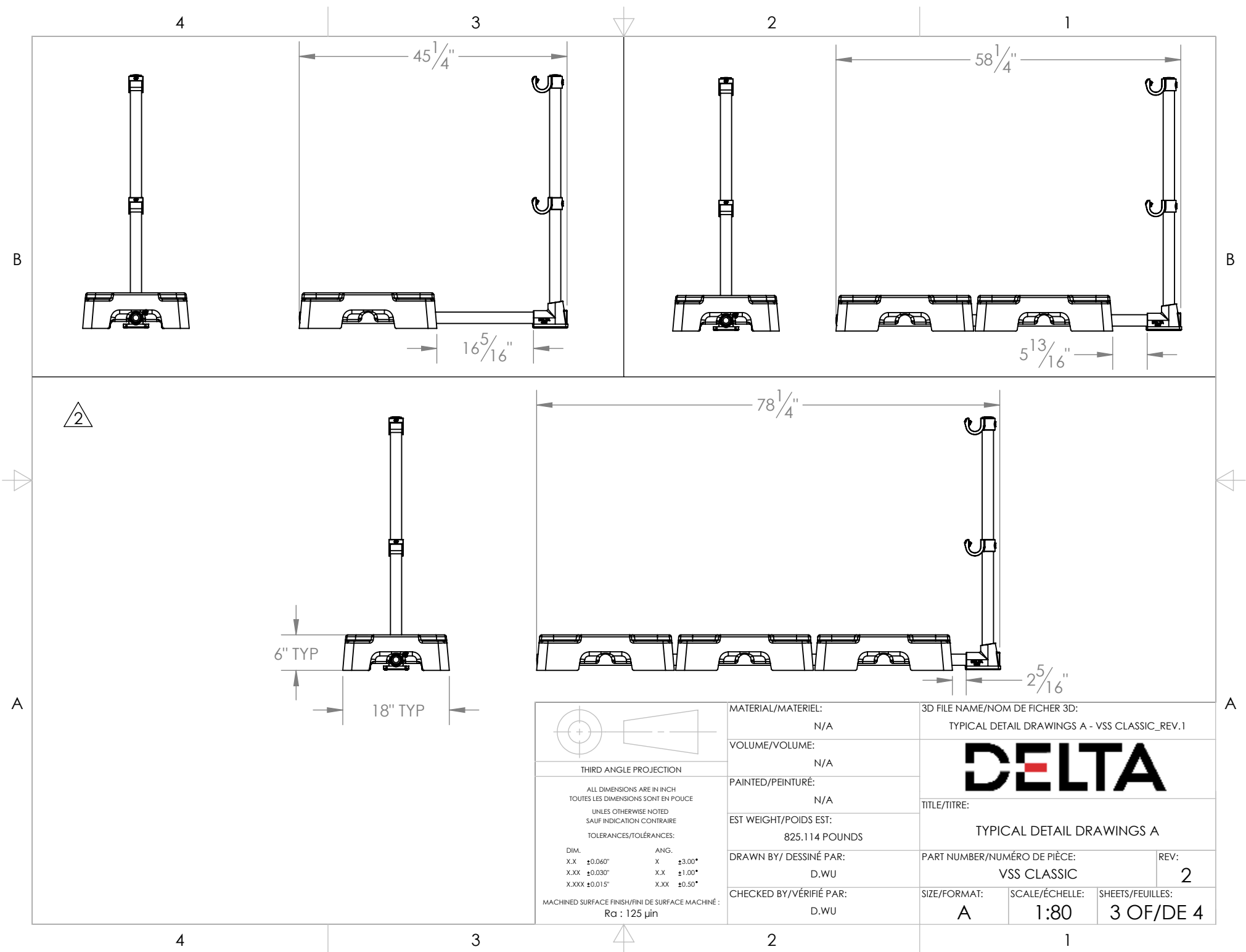

INSTALLED VERTICALLY

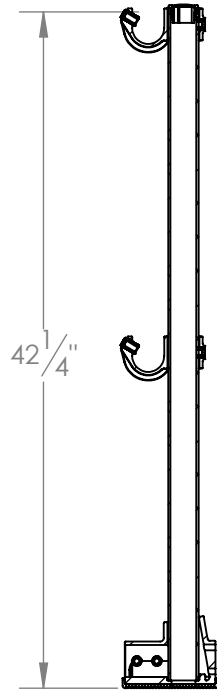
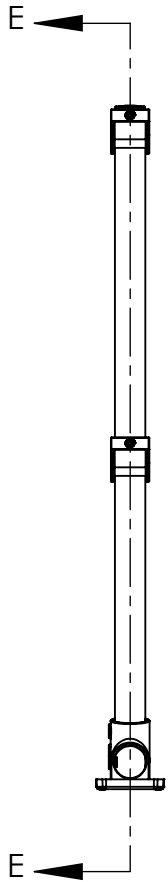

SECTION E-E

INSTALLED AT ANGLE

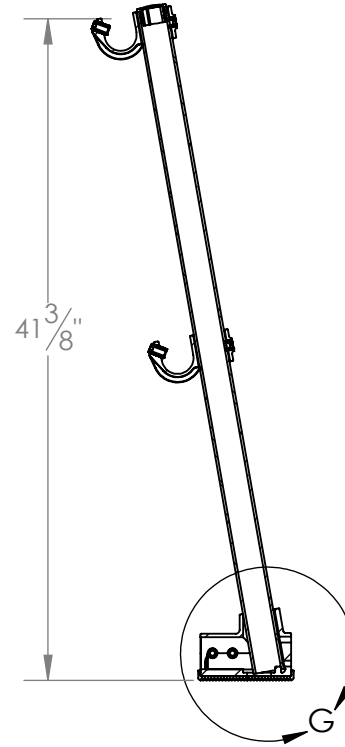
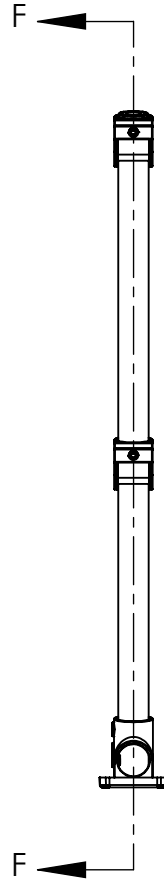

SECTION F-F

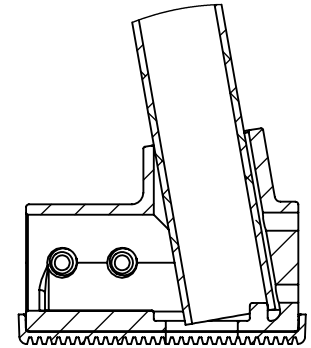

DETAIL G
SCALE 1 : 4

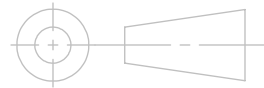

THIRD ANGLE PROJECTION

ALL DIMENSIONS ARE IN INCH
TOUTES LES DIMENSIONS SONT EN POUCE
UNLESS OTHERWISE NOTED
SAUF INDICATION CONTRAIRE

TOLERANCES/TOLÉRANCES:

DIM.	ANG.
X.X ±0.060"	X ±3.00°
X.XX ±0.030"	X.X ±1.00°
X.XXX ±0.015"	X.XX ±0.50°

MACHINED SURFACE FINISH/FINI DE SURFACE MACHINÉ :
Ra : 125 µin

MATERIAL/MATERIEL:

N/A

VOLUME/VOLUME:

N/A

PAINTED/PEINTURÉ:

N/A

EST WEIGHT/POIDS EST:

11.528 POUNDS

DRAWN BY/ DESSINÉ PAR:

D.WU

CHECKED BY/VÉRIFIÉ PAR:

D.WU

3D FILE NAME/NOM DE FICHER 3D:

VPA42001_REV.1

DELTA

TITLE/TITRE:

VERTICAL POST ASM 42" (WITH CL200)

PART NUMBER/NUMÉRO DE PIÈCE:

VPA42001

REV:

2

SIZE/FORMAT:

A

SCALE/ÉCHELLE:

1:12

SHEETS/FEUILLES:

4 OF/DE 4